

12V электрический врезной замок DH150.3

DH-150.3NONC

Electronic bolt lock

UDOHOW Electric Bolt Locks are electric bolt suitable for glass door, wooden door, metal door . We supply integrity equipment to collocate with glass door, swing-in door and so on. Build-in Photo electricity control and low temperature design. The operating principle of Electric Bolt Lock is that the electric power turns into magnetic force. Electric Bolt Lock has two working modes:
one of the mode is door locked when power off.
The another modes is door locked when power on.



► Product Pictures:



1. подходит для всех видов дверей
2. С низким энергопотреблением, защита окружающей среды
3. Функция задержки: 0/3/6 / 9сек

напряжение	12VDC ± 15%
Начать текущий	1200mA
Ток в режиме ожидания	120mA
Удерживающая сила	1000кг
Подходит для	Деревянная дверь, Стеклопанельная дверь, Металлическая дверь
Индукционная дистанция	≥10mm
Рабочая температура	-20 ~ + 55 ° C (14 ~ 131F)
Рабочая влажность	0 ~ 90% (без конденсации)
Вес блокировки	1,2кг

► Production Process

Drilling Armature



Removing The Glue



Lock Surface



Assembling



PCB Test

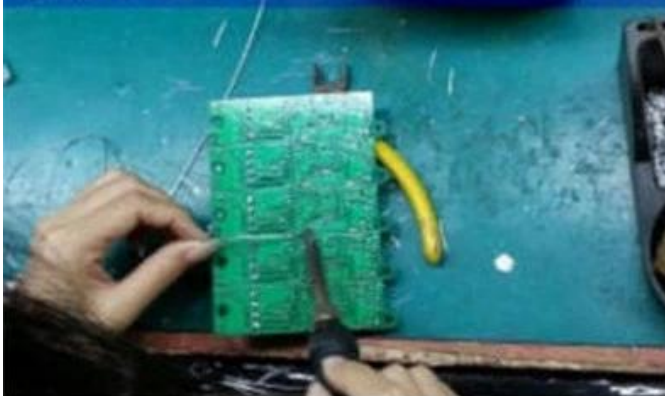

Aluminum Housing Cutting



Pouring Glue



Drilling Of Panel



► Installation

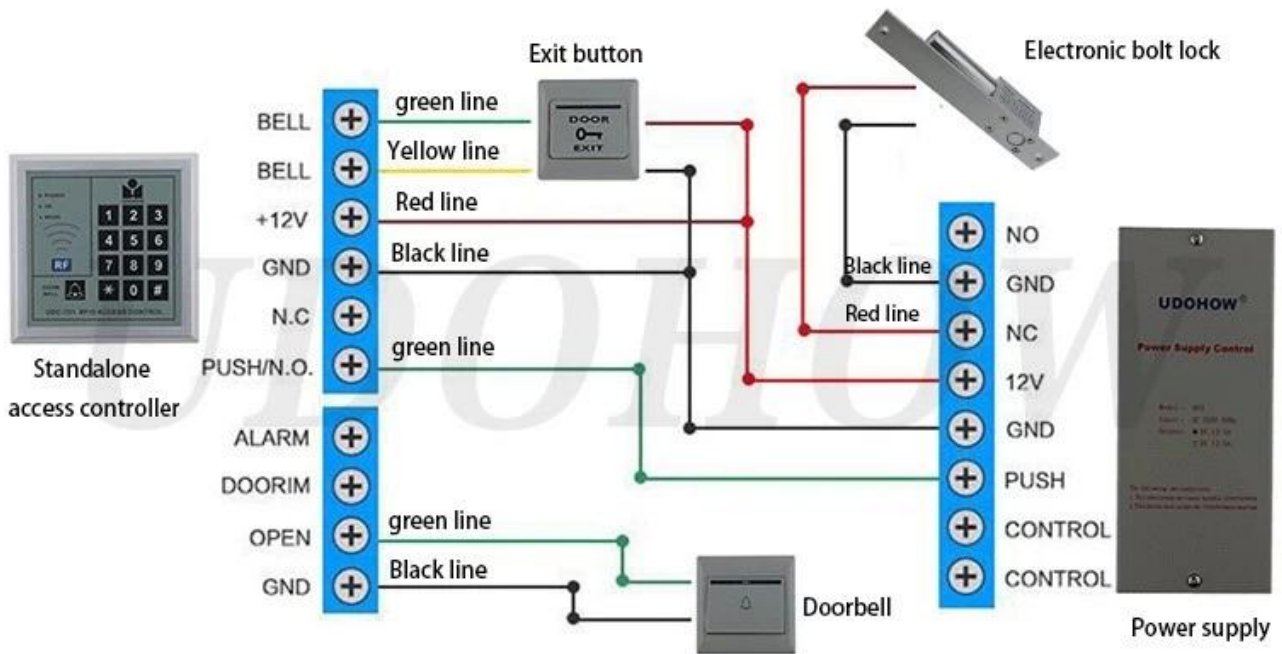

Installation

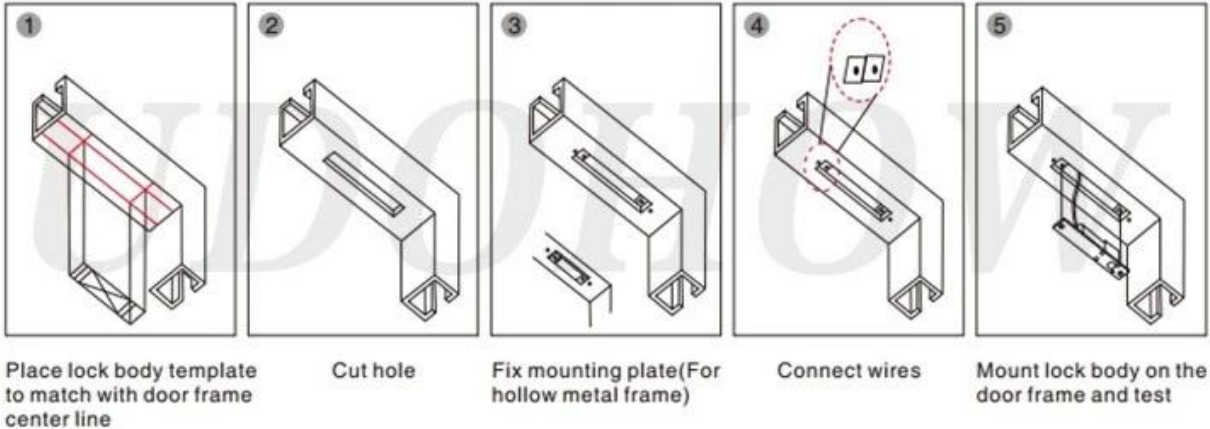

Installation Schematic

Frameless Glass Door

Suitable for 10-15mm glass door, BBK-600/601/602 for Frameless Glass Door.

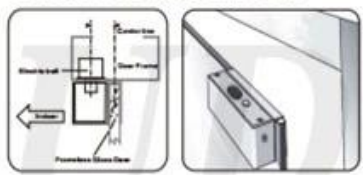

Fully Frameless Glass Door

BBK-700 for Fully Frameless Glass Door

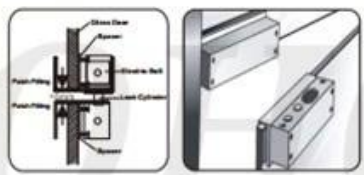

Aluminium Bracket for Narrow Door

BBK-500 for Narrow Door



▶ About us



UDOHOW 鼎昊

Our company is a high-tech enterprise. We have been specialized in the R&D, production and marketing of Access Control Products. Products include Hotel Locks, Fingerprint Locks, Keypad Locks, Electromagnetic Locks, Electric Locks, Electric Bolt Locks, Power Supplies for Access Control, Access Controllers, Access Control Boards, Access Readers, RFID Cards, Exit Buttons and Switches, Time Attendance Access Controls, Door Closers, Fingerprint Access Controllers, and Cabinet Locks.



UDOHOW

UDOHOW



UDOHOW

UDOHOW

Products have Certification of CE, ROHS, FCC. From the lock - lock body - electronic board, UDOHOW masters the international advanced system lock technology and has a high quality assurance.



The company Upholds the business philosophy of "Endless innovation, good faith forever", Because of the high quality of service, we have won the trust and support of our business friends. Our products are exported to the United States, France, Spain, Russia, Singapore, Thailand, Turkey, Holland and other countries.

