

## Sistema de Controle de Acesso 180KG 350lbs Única Porta 12V Fechadura Magnética Elétrica Fechamento Eletromagnético

### Características do bloqueio eletromagnético:

Dimensão: L170 × W35 × H26, peso: 1.2kg

tração: 180kg, tensão: DC12V

Consumo atual: 12V / 350mA

### Especificação técnica de bloqueio eletromagnético:

Força de retenção: 180kg (350Lbs)

Tensão: 12VDC

Tração atual: 12V / 100mA

Apropriado para: armário de arquivo, armário de exposição

Temperatura da superfície:  $\leq + 20^{\circ} \text{C}$

Temperatura de Operação:  $10 \sim + 55^{\circ} \text{C}$  (14-131F)

Umidade adequada:  $0 \sim 90\%$  (sem condensação)

Acabamentos para Shell: Alumínio anodizado

Acabamentos Magnéticos: Zinco

Acabamentos para Armature: Zinc

### Imagem de detalhe de bloqueio magnético

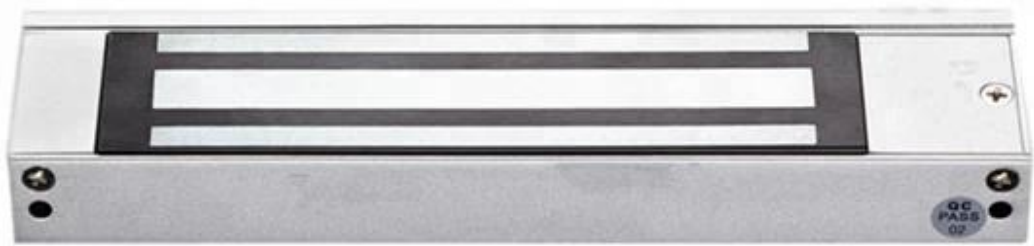



# ► Optional Accessories

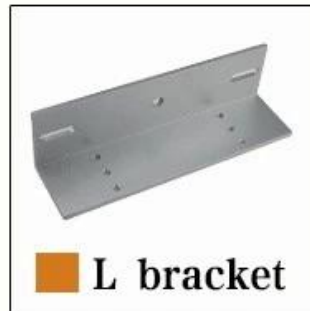

## UDOHOW Magnetic lock Series

|   |   |   |
|---|---|---|
| <b>Holding Force : 180kg/375lbs</b>   |   |   |
| <b>DH-180G</b>  | <b>DH-180A</b>  | <b>DH-180GS</b>   |
|   |   |   |
| <b>Holding Force : 280kgs/600lbs</b>  |   |   |
| <b>DH-280G</b>  | <b>DH-280A</b>  | <b>DH-280GS</b>   |
|  |  |  |
| <b>Holding Force : 350kgs/750lbs</b>  |   |   |
| <b>DH-350G</b>  | <b>DH-350A</b>  | <b>DH-350GS</b>   |
|  |  |  |
| <b>Holding Force:60KG/100lbs</b>  |   | <b>Holding Force : 500kg/1200lbs</b>  |
| <b>DH-60G</b>   |   | <b>DH-500G</b>  |
|  |   |   |

# ► Installation

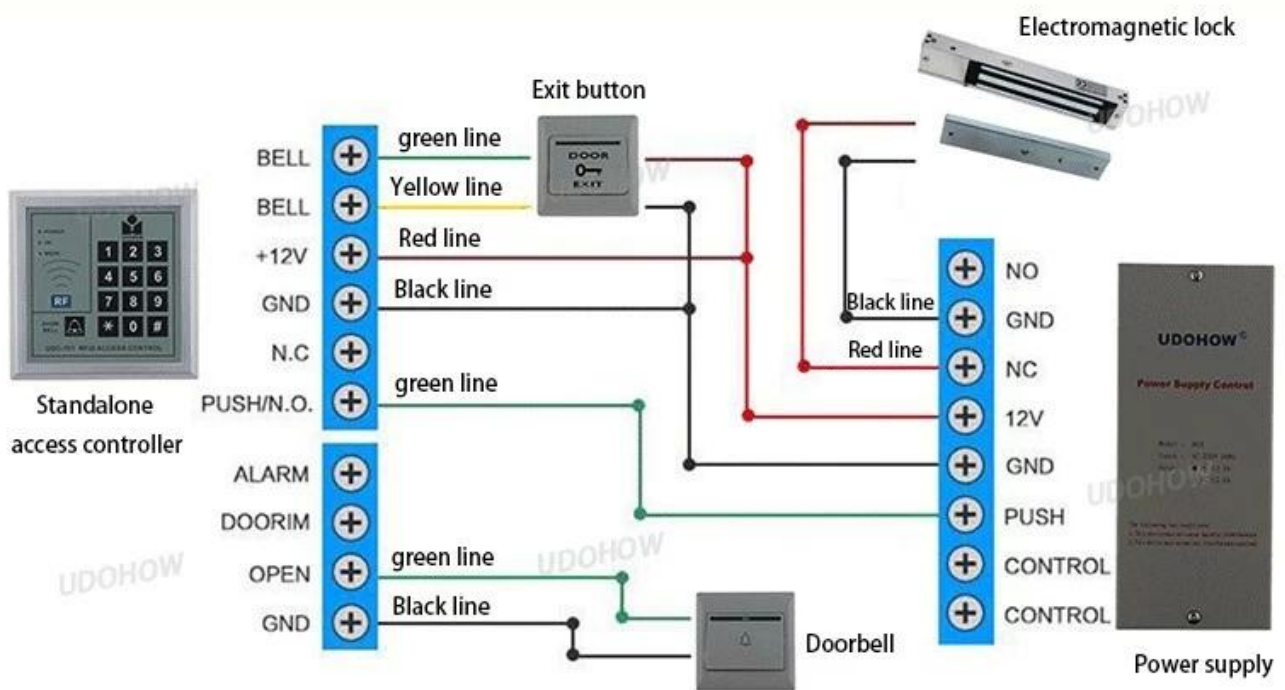

# ► About us



**UDOHOW 鼎昊**

Our company is a high-tech enterprise. We have been specialized in the R&D, production and marketing of Access Control Products. Products include Hotel Locks, Fingerprint Locks, Keypad Locks, Electromagnetic Locks, Electric Locks, Electric Bolt Locks, Power Supplies for Access Control, Access Controllers, Access Control Boards, Access Readers, RFID Cards, Exit Buttons and Switches, Time Attendance Access Controls, Door Closers, Fingerprint Access Controllers, and Cabinet Locks.



UDOHOW

UDOHOW



UDOHOW

UDOHOW

**Products have Certification of CE, ROHS, FCC. From the lock - lock body - electronic board, UDOHOW masters the international advanced system lock technology and has a high quality assurance.**



The company Upholds the business philosophy of "Endless innovation, good faith forever", Because of the high quality of service, we have won the trust and support of our business friends. Our products are exported to the United States, France, Spain, Russia, Singapore, Thailand, Turkey, Holland and other countries.



**CONTACT US**



## **Sincerely for your service**

**You are welcome to come to consult**

**Contact:** Winnie Liang

**Cellphone/Wechat/Whatsapp:** +86 13602510930

**Skype:** udohow1

**Email:** info@udohow.com

**Web:** www.udohow.com

**Click Back Home**