

I-access ang System ng Pag-access ng 180KG 350lbs Single Door 12V Electric Magnetic Lock Electromagnetic Lock

Mga tampok ng electro magnetic lock:

Laki: L170 × W35 × H26, Timbang: 1.2kg

hilahin: 180kg, Boltage: DC12V

Kasalukuyang pagkonsumo: 12V / 350mA

Teknikal na Pagtukoy ng electro magnetic lock:

Holding Force: 180kg (350Lbs)

Boltage: 12VDC

Kasalukuyang Gumuhit: 12V / 100mA

Angkop para sa: File Cabinet, Ipakita ang Gabinete

Ibabaw ng Templo: $\leq + 20^{\circ} \text{C}$

Operating Temp: $10 \sim + 55^{\circ} \text{C}$ (14-131F)

Angkop na kahalumigmigan: $0 \sim 90\%$ (hindi nakakapag-condens)

Tapos na para sa Shell: Anodized aluminyo

Tapos na para sa Magnetic: Zinc

Tapos na para sa Armature: Zinc

Larawan ng detalye ng Magnetic Lock

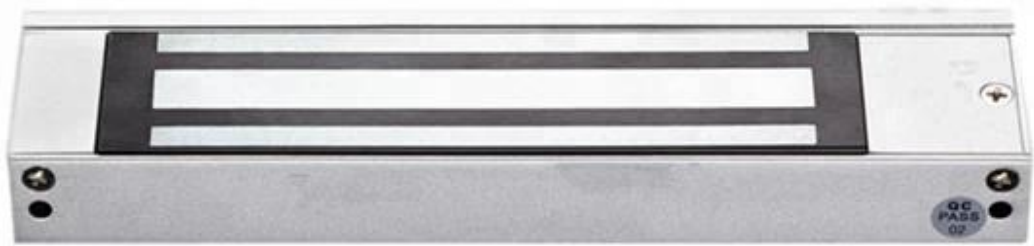



► Optional Accessories

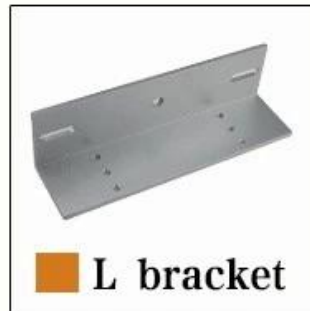

UDOHOW Magnetic lock Series

| Holding Force : 180kg/375lbs | | |
|---|---|---|
| DH-180G | DH-180A | DH-180GS |
|  |  |  |
| Holding Force : 280kgs/600lbs | | |
| DH-280G | DH-280A | DH-280GS |
|  |  |  |
| Holding Force : 350kgs/750lbs | | |
| DH-350G | DH-350A | DH-350GS |
|  |  |  |
| Holding Force:60KG/100lbs | | Holding Force : 500kg/1200lbs |
| DH-60G | | DH-500G |
|  | |  |

► Installation

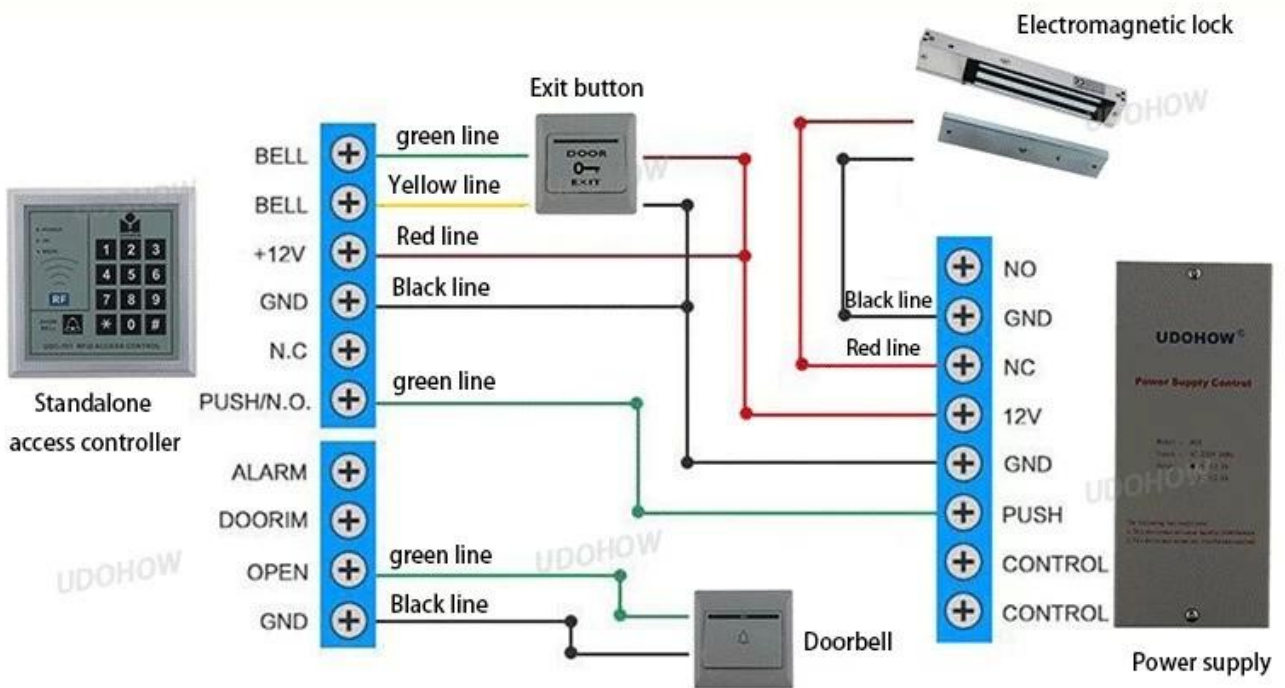

▶ About us



UDOHOW 鼎昊

Our company is a high-tech enterprise. We have been specialized in the R&D, production and marketing of Access Control Products. Products include Hotel Locks, Fingerprint Locks, Keypad Locks, Electromagnetic Locks, Electric Locks, Electric Bolt Locks, Power Supplies for Access Control, Access Controllers, Access Control Boards, Access Readers, RFID Cards, Exit Buttons and Switches, Time Attendance Access Controls, Door Closers, Fingerprint Access Controllers, and Cabinet Locks.



UDOHOW

UDOHOW



UDOHOW

UDOHOW

Products have Certification of CE, ROHS, FCC. From the lock - lock body - electronic board, UDOHOW masters the international advanced system lock technology and has a high quality assurance.



The company Upholds the business philosophy of "Endless innovation, good faith forever", Because of the high quality of service, we have won the trust and support of our business friends. Our products are exported to the United States, France, Spain, Russia, Singapore, Thailand, Turkey, Holland and other countries.



CONTACT US



Sincerely for your service

You are welcome to come to consult

Contact: Winnie Liang

Cellphone/Wechat/Whatsapp: +86 13602510930

Skype: udohow1

Email: info@udohow.com

Web: www.udohow.com

Click Back Home