

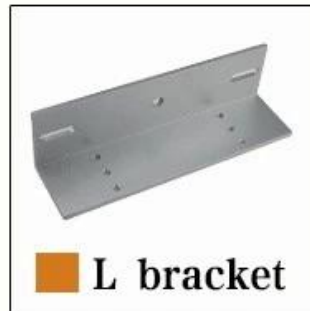

► Optional Accessories



UDOHOW Magnetic lock Series

Holding Force : 180kg/375lbs		
DH-180G	DH-180A	DH-180GS
		
Holding Force : 280kgs/600lbs		
DH-280G	DH-280A	DH-280GS
		
Holding Force : 350kgs/750lbs		
DH-350G	DH-350A	DH-350GS
		
Holding Force:60KG/100lbs		Holding Force : 500kg/1200lbs
DH-60G		DH-500G
		

▶ Installation

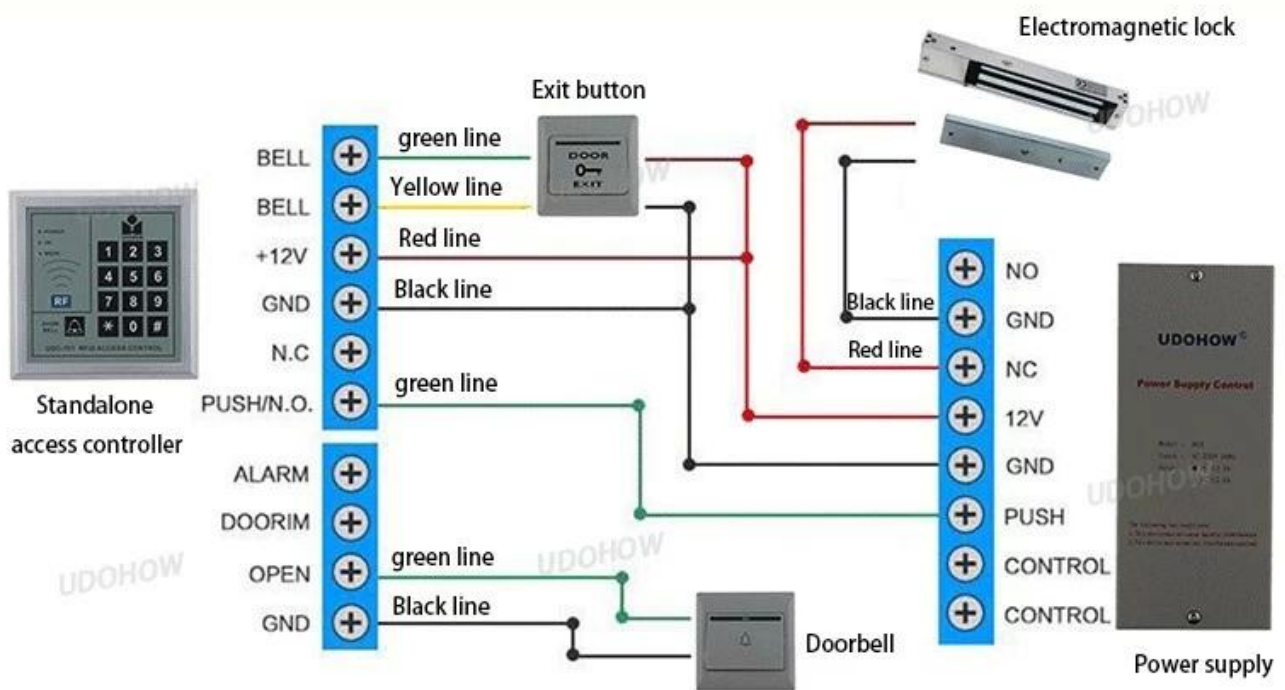

▶ About us



UDOHOW 鼎昊

Our company is a high-tech enterprise. We have been specialized in the R&D, production and marketing of Access Control Products. Products include Hotel Locks, Fingerprint Locks, Keypad Locks, Electromagnetic Locks, Electric Locks, Electric Bolt Locks, Power Supplies for Access Control, Access Controllers, Access Control Boards, Access Readers, RFID Cards, Exit Buttons and Switches, Time Attendance Access Controls, Door Closers, Fingerprint Access Controllers, and Cabinet Locks.



UDOHOW

UDOHOW



UDOHOW

UDOHOW

Products have Certification of CE, ROHS, FCC. From the lock - lock body - electronic board, UDOHOW masters the international advanced system lock technology and has a high quality assurance.



The company Upholds the business philosophy of "Endless innovation, good faith forever", Because of the high quality of service, we have won the trust and support of our business friends. Our products are exported to the United States, France, Spain, Russia, Singapore, Thailand, Turkey, Holland and other countries.



CONTACT US



Sincerely for your service

You are welcome to come to consult

Contact: Winnie Liang

Cellphone/Wechat/Whatsapp: +86 13602510930

Skype: udohow1

Email: info@udohow.com

Web: www.udohow.com

Click Back Home