

## ZL Halterung für 180kg 280kg elektrisch [magnetisches Türschloss](#)

### Produkteinführung

ZL-Formhalterung für elektromagnetische Verriegelung

Modell: DH-280ZL / DH-180ZL

Geeignet für: Holztür, feuerfeste Tür

DH-280ZL Verwendung für eintüriges elektromagnetisches Schloss (600 Pfund)

DH-180ZL Verwendung für eintüriges elektromagnetisches Schloss (300 Pfund)







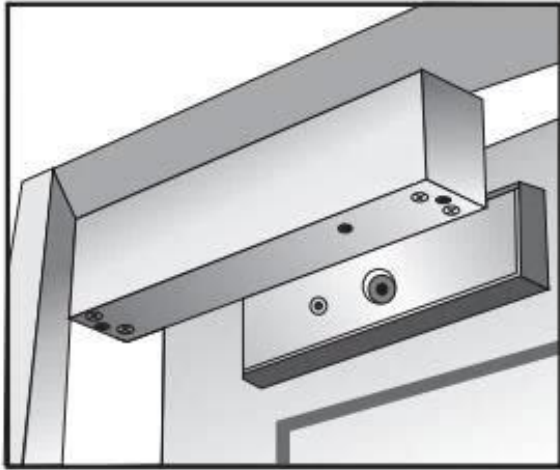

Armature Plate

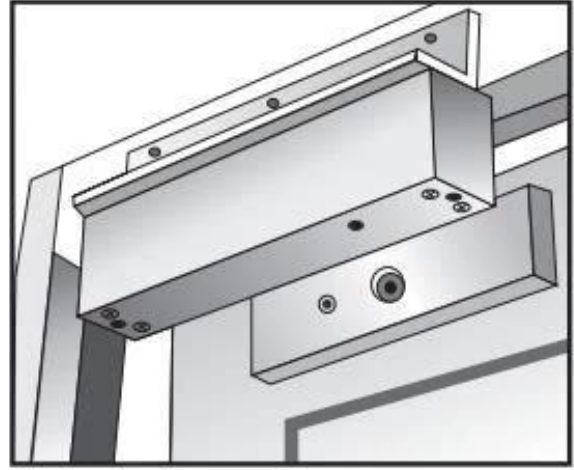

L BRACKET

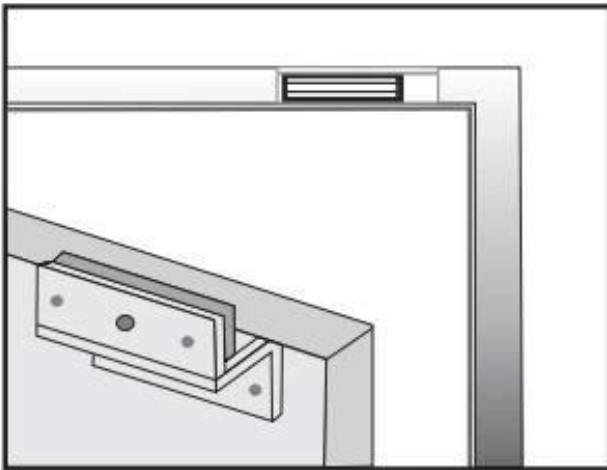

ZL BRACKET

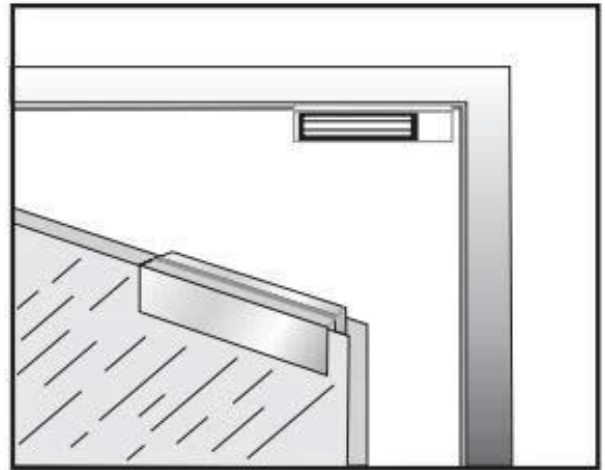

U BRACKET

# ► Optional Accessories

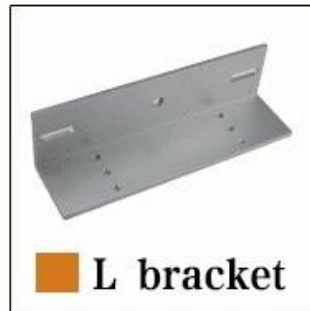

## UDOHOW Magnetic lock Series

Holding Force : 180kg/375lbs		
DH-180G	DH-180A	DH-180GS
		
Holding Force : 280kgs/600lbs		
DH-280G	DH-280A	DH-280GS
		
Holding Force : 350kgs/750lbs		
DH-350G	DH-350A	DH-350GS
		
Holding Force:60KG/100lbs		Holding Force : 500kg/1200lbs
DH-60G		DH-500G
		

# Unsere Unternehmen

## ABOUT US COMPANY INTRODUCTION

UDOHOW Electronics Co., Limited is a high-tech enterprise located in Guangdong Province, China. We're one of the leading manufacturers specialized in Intelligent Locks and Access Control Products including: Hotel Locks, Fingerprint Locks, Keypad Locks, Cabinets Locks, Electric Locks, Exit Switches and other related security access control products.

Our products have received good comments and trust of customers by superior quality, advanced innovation and considerate service.

[+ View More](#)



## FACTORY / WORKSHOP / EXHIBITION



# Unsere Zertifikate

## OUR CERTIFICATE



# Kontaktiere uns

**CONTACT US**



## **Sincerely for your service**

**You are welcome to come to consult**

**Contact:** Winnie Liang

**Cellphone/Wechat/Whatsapp:** +86 13602510930

**Skype:** udohow1

**Email:** info@udohow.com

**Web:** www.udohow.com

**Click Back Home**