

عالي الأمان الصين 280 كجم / 600 رطل ضد للماء كهربائي مغناطيسي باب قفل إلى عن على باب التمكن من مراقبة النظام

**المواصفات الفنية للقفل الكهربائي المغناطيسي**

إدخال جهد العمل: DC12V / 24V

500 mA / 250mA العمل الحالي □

درجة حرارة التشغيل: -10 ~ + 55 درجة فهرنهايت 14-131 فهرنهايت □

رطوبة التشغيل: 0-90%

القوة القابضة □ 280 كجم / 600 رطل

الوزن □ 1.97 كجم

الحجم □ 253 \* 25 \* 48 ملم

## DH-280G Magnetic Lock

# STRONG SUCTION PREVENTION DISMANTLING

Aluminum Alloy Material



### Security Burglarproof

Internal six angle screw design



### Detection Feedback

Often open and normally closed signal



### Good Material

High strength aluminum alloy

# Product Parameters

High Quality Life Choices

Size	253Lx25Wx48H(mm)
Holding Force	280kg(600Lbs)
Input Voltage	12 or 24VDC
Current Draw	12V/500mA or 24V/250mA
Suitable	Wooden door , Glass door , Metal door , Fireproof door
Surface Temp	$\leq +20^{\circ}\text{C}$
Operating Temp	$-10\sim +55^{\circ}\text{C}$ (14-131F)
Humidity	0~90%(non-condensing)
Cover Finish	Anodized aluminum
Lock Finish	Zinc
Armature Plate Finish	Zinc
Weight	2.1KG

Diagram(unit:mm)

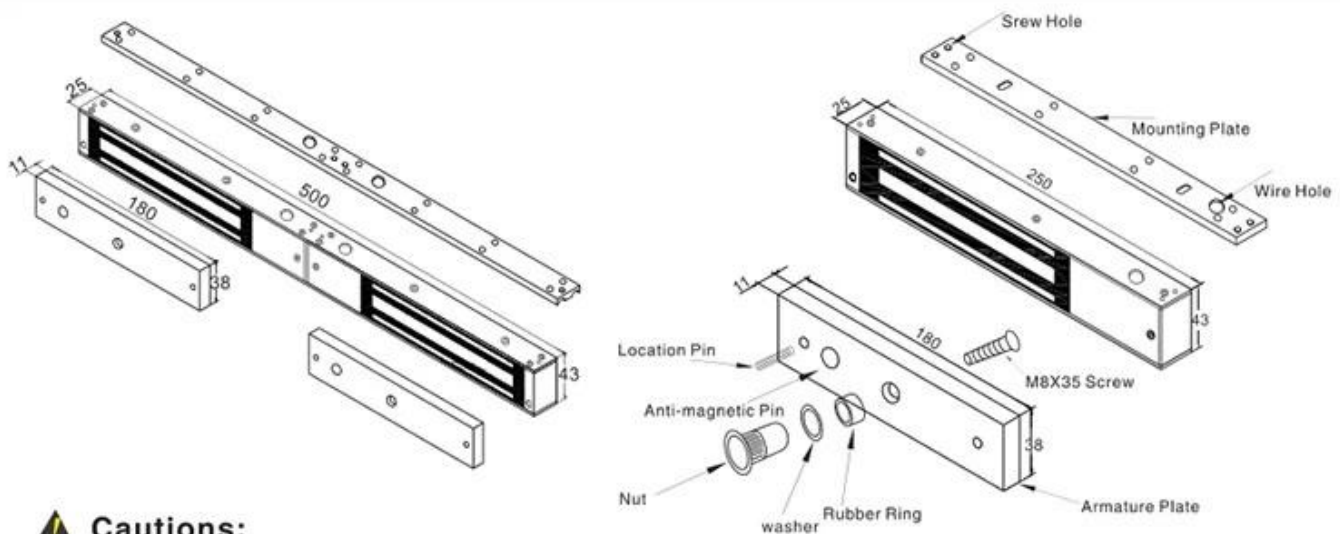

## ⚠ Cautions:

- The screw of armature plate should not be fixed too tight. Proper elasticity should be guaranteed for the rubber ring so that the armature plate can adjust itself to the appropriate position.
- Check the jumper's position before connecting. Figure out it represents 12VDC or 24VDC.
- Please keep the surface of the lock clean, or the force will be reduced because of the dust, glue or scotch tape on it.

# ► Installation

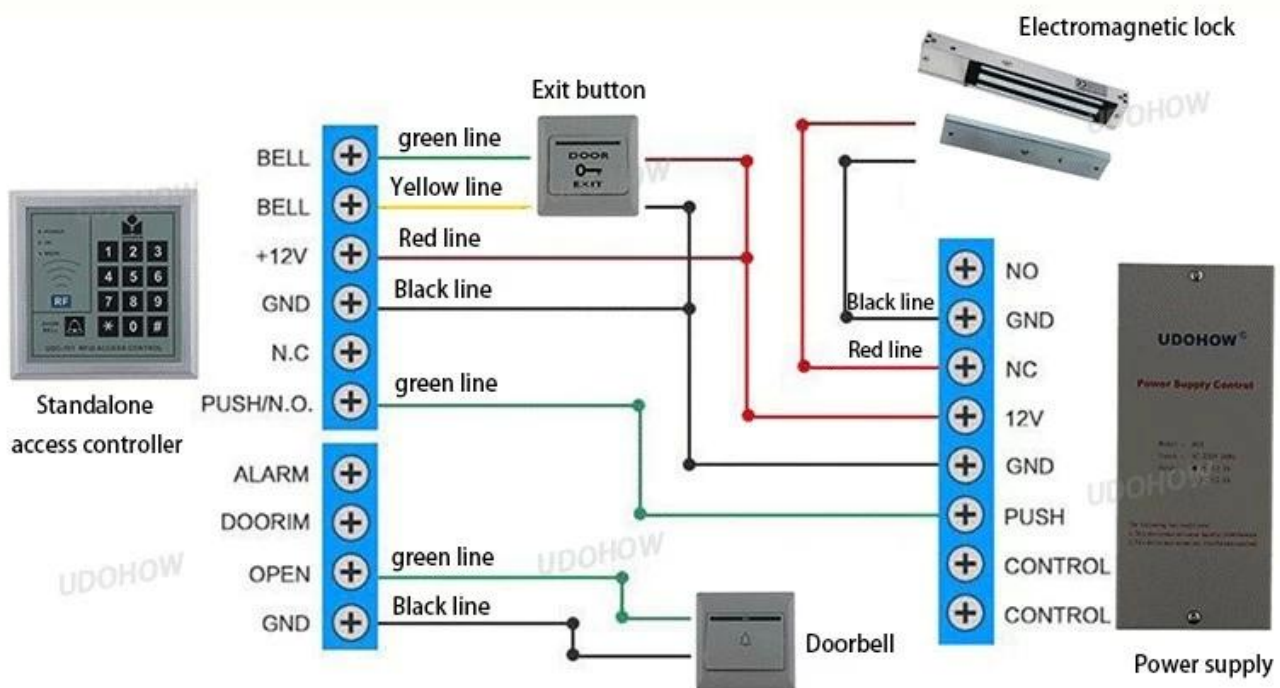

## Specification

Model	Size(unit:mm)	Voltage	Current	Holding Force	Lock Signal	Door Signal	Door
DH-280G	250Lx48.5Wx25H	12/24VDC	12V/500mA 24V/250mA	280kg(600Lbs)	No	No	Single Door
DH-280GS	500Lx48.5Wx25H	12/24VDC	12V/500mAx2 24V/250mAx2	280kgx2(600Lbsx2)	No	No	Double Door
DH-280GF	250Lx48.5Wx25H	12/24VDC	12V/500mA 24V/250mA	280kg(600Lbs)	Yes	NO(B),NC(R) COM(Y)	Single Door
DH-280GSF	500Lx48.5Wx25H	12/24VDC	12V/500mAx2 24V/250mAx2	280kgx2(600Lbsx2)	Yes	NO(B),NC(R) COM(Y)	Double Door

## Bracket Installation

Different brackets are available according to different types of doors. For example, narrow door, frameless glass door and inward opening door.

### L Bracket-For outward opening door

When the door frame thickness is less than 42mm, L bracket is needed.

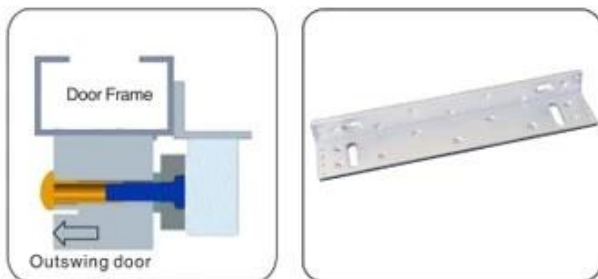

### ZL Bracket-For inward opening door

For inward opening door, ZL bracket is needed.

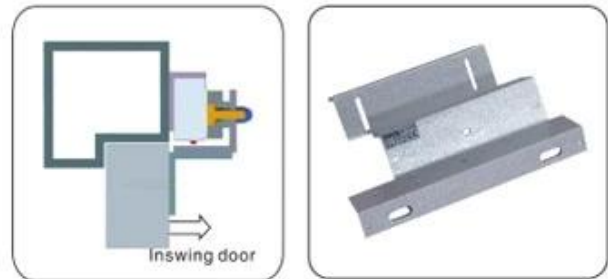

### U Bracket

For the frameless glass door. U bracket is needed.

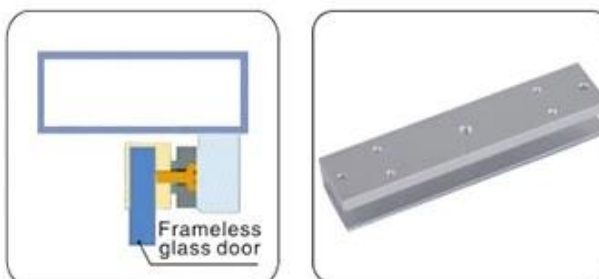

### I Bracket for armature plate

When the door frame is too thick, I bracket is needed.

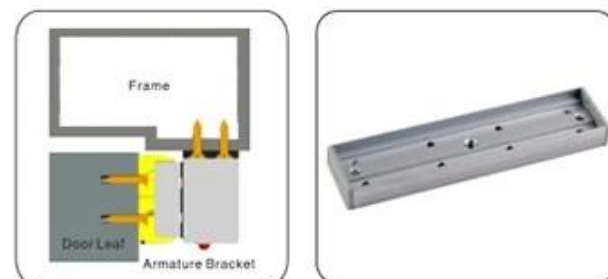

## Installation Instruction

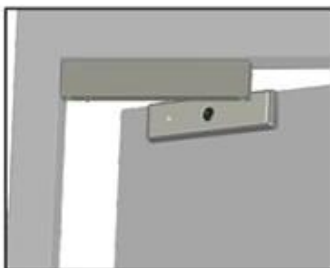

Demonstration of I Bracket Installation

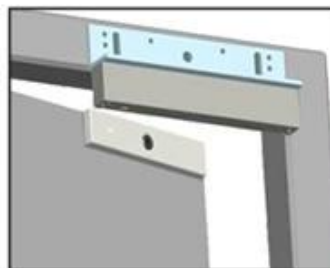

Demonstration of L Bracket Installation

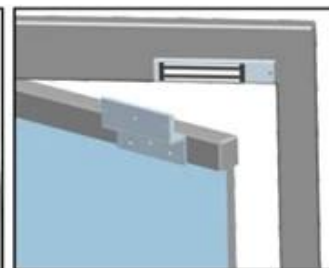

Demonstration of ZL Bracket Installation

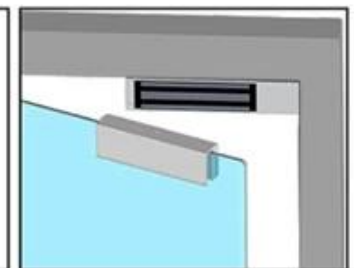

Demonstration of UL Bracket Installation

# ▶ About us



**UDOHOW 鼎昊**

Our company is a high-tech enterprise. We have been specialized in the R&D, production and marketing of Access Control Products. Products include Hotel Locks, Fingerprint Locks, Keypad Locks, Electromagnetic Locks, Electric Locks, Electric Bolt Locks, Power Supplies for Access Control, Access Controllers, Access Control Boards, Access Readers, RFID Cards, Exit Buttons and Switches, Time Attendance Access Controls, Door Closers, Fingerprint Access Controllers, and Cabinet Locks.



UDOHOW

UDOHOW



UDOHOW

UDOHOW

**Products have Certification of CE, ROHS, FCC. From the lock - lock body - electronic board, UDOHOW masters the international advanced system lock technology and has a high quality assurance.**



The company Upholds the business philosophy of "Endless innovation, good faith forever", Because of the high quality of service, we have won the trust and support of our business friends. Our products are exported to the United States, France, Spain, Russia, Singapore, Thailand, Turkey, Holland and other countries.



**CONTACT US**



**Sincerely for your service**

**You are welcome to come to consult**

**Contact:** Winnie Liang

**Cellphone/Wechat/Whatsapp:** +86 13602510930

**Skype:** udohow1

**Email:** info@udohow.com

**Web:** www.udohow.com

**Click Back Home**